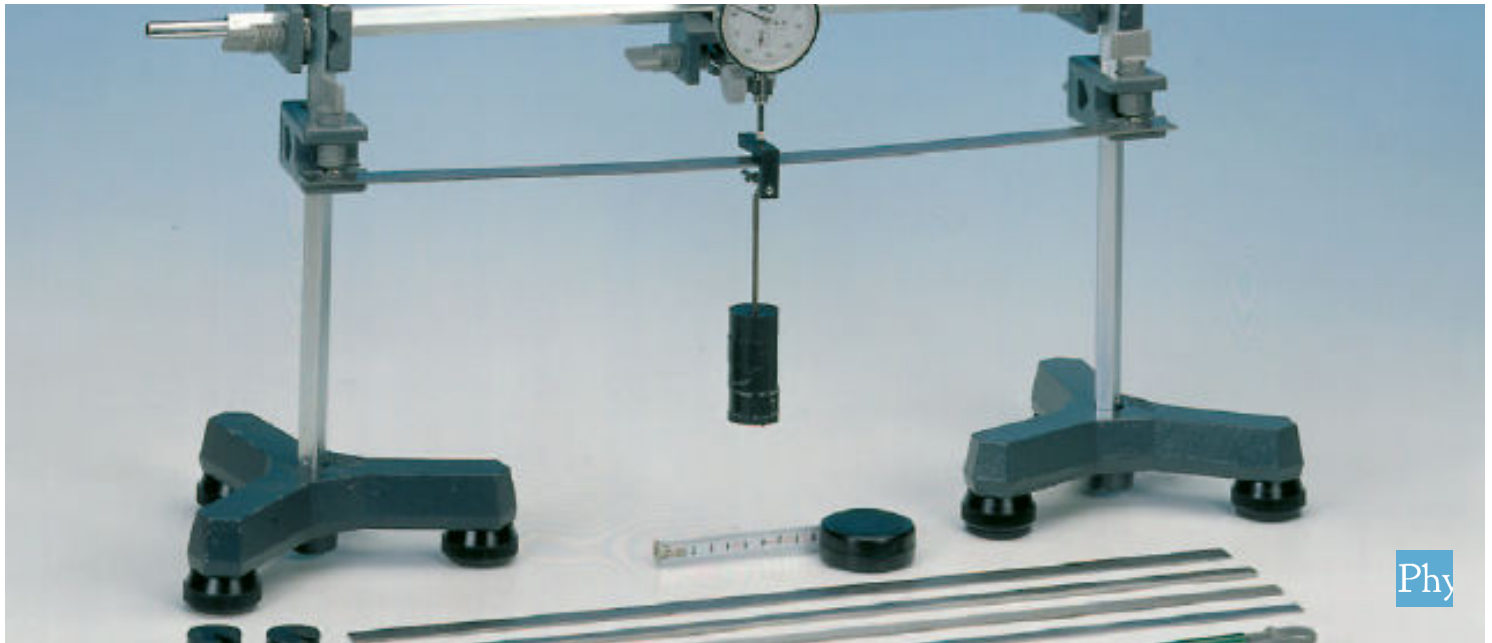






# Modulus of elasticity



Physics		Mechanics		Fabric & material properties	
Applied Science	Engineering	Applied Mechanics	Statics		
Applied Science	Engineering	Materials Science	Mechanical Properties		
Applied Science	Medicine	Biomechanics			
 Difficulty level	 Group size	 Preparation time	 Execution time		
easy	2	45+ minutes	45+ minutes		

**PHYWE**  
excellence in science

# General information

## Application

**PHYWE**  
excellence in science

Fig.1: Experimental set-up

Solid matter changes form under the application of a force. The exact knowledge about the behaviour of such changes is very important in construction. The modulus of elasticity is used to describe this behaviour in mathematical way.

## Other information (1/2)

**PHYWE**  
excellence in science**Prior****knowledge****Main****principle**

The prior knowledge for this experiment is found in the Theory section.

A flat bar is supported at two points. It is bent by the action of a force acting at its centre. The modulus of elasticity is determined from the bending and the geometric data of the bar.

## Other information (2/2)

**PHYWE**  
excellence in science**Learning****objective****Tasks**

The goal of this experiment is to determine the modulus of elasticity.

1. Determination of the characteristic curve of the dial gauge
2. Determination the bending of flat bars as a function of force, the thickness, at constant force, the width, at constant force, the distance between the support points at constant force
3. Determination the modulus of elasticity of steel, aluminium and brass.

## Theory (1/4)

If a body is regarded as a continuum, and  $\vec{r}_0$  or  $\vec{r}$  defines the local vector of a point P in its undeformed and deformed state respectively, then, for small displacement vectors

$$\vec{u} = \vec{r} - \vec{r}_0 \equiv (u_1, u_2, u_3)$$

the deformation tensor  $\vec{d}$  is:

$$d_{ik} = \frac{\partial u_i}{\partial x_k} + \frac{\partial u_k}{\partial x_i}$$

The forces  $d\vec{F}$  which act upon an element of volume of the body whose edges are intersected parallel to the coordinate surfaces will be described by the stress tensor  $\hat{\tau}$

This allocates a stress  $\vec{p}$  to each area element  $dA$  defined by the unit vector  $\vec{e}$  in the direction of the normal.

$$\vec{p} = \frac{d\vec{F}}{dA}$$

$$\vec{p} = \vec{e} \odot \vec{\tau}$$

From Hooke's Law we obtain the relationship between  $\hat{d}$  and  $\hat{\tau}$ :

$$\tau_{ik} = \sum_{l,m} c_{ik}^{l,m} d_{lm}$$

## Theory (2/4)

The tensor  $\hat{e}$  is symmetrical for an elastic body so that of the 81 components only 21 remain. This number is reduced to 2 for the isotropic elastic body, i.e. the modulus of elasticity E and either the shear modulus G or the Poisson ratio  $\mu$ :

$$\tau_{11} = \frac{E}{1+\mu} (d_{11} + \frac{\mu}{1-2\mu} (d_{11} + d_{22} + d_{33}))$$

$$\tau_{12} = G d_{12} = \frac{1}{2} \cdot \frac{E}{1+\mu} \cdot d_{12}$$

and analogously for  $\tau_{22}, \tau_{33}, \tau_{13}, \tau_{23}$

If a force acts in only one direction then

$$\tau_{22} = \tau_{33} = 0$$

so we obtain (2)

$$\tau_{11} = E \cdot d_{11}$$

If a bar of height b and width a, supported at both ends by supports (separated by a distance L), is subjected to a force  $F_y$  acting at its centre, it behaves like a bar supported in the middle, its two ends being subjected to a force  $F_y/2$  in the opposing direction. In order to express the bending  $\lambda$  as a function of the modulus of elasticity E, let us first consider an element of volume

## Theory (3/4)


 PHYWE  
 excellence in science

$$dV = d \cdot a \cdot b$$

the upper layer of which is shortened on bending, and the bottom layer lengthened. The length of the central layer remains unchanged (neutral fibre).

In fig. 2, I and II denote the sides before and after deformation.

Using the symbols given in fig. 2, we obtain:

$$d\lambda = x \cdot d\varphi = \frac{2\sigma x}{b}$$

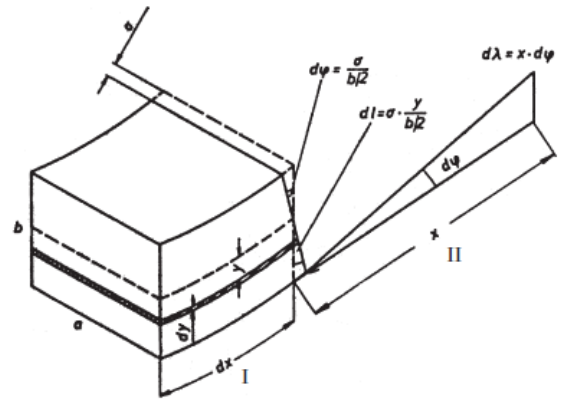


Fig. 2: Deformation of a bar.

## Theory (4/4)


 PHYWE  
 excellence in science

The elastic force  $dF_x$  which produces the extension  $dl$ , according to (1), is

$$\frac{dF_x}{ds} = E \frac{dl}{dx}$$

where  $ds = a \cdot dy$  is the area of the rotated layer.

The force produces a torque

$$dT_z = y dF_x = \frac{2Ea\sigma}{b \cdot dx} y^2 dy$$

The sum of these torques produced by the elastic forces must be equal to the torque produced by the external force  $F_y/2$ .

$$\frac{Ea\sigma b^2}{6dx} = \frac{F_y}{2} \cdot x$$

from which we obtain

$$d\lambda = \frac{6F_y x^2}{Eab^3} dx$$

and, after integration, the total bending

$$\lambda = \frac{1}{4} \cdot \left(\frac{L}{B}\right)^3 \cdot \frac{1}{a} \cdot \frac{F_y}{E}.$$

## Equipment

Position	Material	Item No.	Quantity
1	Dial gauge 10/0.01 mm	03013-00	1
2	Holder for dial gauge	03013-01	1
3	Flat bars, set	17570-00	1
4	Knife-edge with stirrup	03015-00	1
5	Bolt with knife-edge	02049-00	2
6	Weight holder, 10 g	02204-00	1
7	Spring balance, transparent, 1 N	03065-02	1
8	Tripod base PHYWE	02002-55	2
9	Support rod, stainless steel, l = 250 mm, d = 10 mm	02031-00	2
10	Support rod, stainless steel, 750 mm	02033-00	1
11	Right angle clamp expert	02054-00	5
12	Slotted weight, black, 10 g	02205-01	10
13	Slotted weight, black, 50 g	02206-01	6
14	Vernier calliper stainless steel 0-160 mm, 1/20	03010-00	1
15	Measuring tape, l = 2 m	09936-00	1
16	Fish line, l. 100m	02090-00	1



# Setup and Procedure

## Setup

The set up is as shown in Fig. 1. The dial gauge is mounted on the knife edge with stirrup. The flat bars must be positioned accurately on the two supporting knife edges having the possibility to move in x and y direction. The geometric data of the set up and the bars must be recorded several times or at different positions.

As the dial gauge possesses a restoring force which obeys Hooke's Law  $F \sim s$ , its characteristic curve must first of all be determined.

## Procedure (1/2)

**PHYWE**  
excellence in science

The resulting force  $F_r$  of the dial gauge is the sum of

$$F_r = F_h + F_f \text{ where}$$

$$F_h = \text{Static friction force (constant)}$$

$$F_f = \text{restoring force (} F \sim s \text{)}$$

Since the static friction force always acts opposed to the direction of motion, care should be taken of constant direction of force while recording of the characteristic curve of the dial gauge as well as during performance of the experiment.

Additionally, the plunger is manually raised (the probe is unloaded) and then gently lowered. Due to this procedure the resulting force  $F$  is:

$$F_r = F_f - F_h$$

### Characteristic curve of the dial gauge:

Dynamometer and plunger of the dial gauge are so mounted, that the dial gauge shows full deflection.

Through a reduction of the tension of force of the dynamometer a force results according to the above conditions.

## Procedure (2/2)

**PHYWE**  
excellence in science

With the help of the spring balance the characteristic curve of the dial gauge has to be recorded.

During experimentation the forces must be corrected accordingly.

This means the resulting force  $F$  must be calculated.

Hence, the effective force is the sum of the weights of the additional masses and the resulting force of the dial gauge.

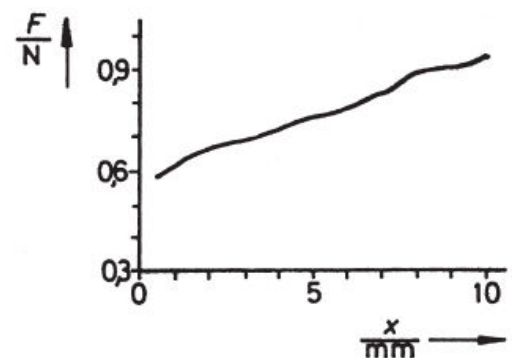


Fig. 3: Characteristic curve of a dial gauge.



# Evaluation

## Results (1/3)

Table 1: The modulus of elasticity for different materials

Material	Dimensions [mm]	$E$ [ $\text{N} \cdot \text{m}^{-2}$ ]
Steel	$10 \times 1.5$	$2.059 \cdot 10^{11}$
Steel	$10 \times 2$	$2.063 \cdot 10^{11}$
Steel	$10 \times 3$	$2.171 \cdot 10^{11}$
Steel	$15 \times 1.5$	$2.204 \cdot 10^{11}$
Steel	$20 \times 1.5$	$2.111 \cdot 10^{11}$
Aluminium	$10 \times 2$	$6.702 \cdot 10^{10}$
Brass	$10 \times 2$	$9.222 \cdot 10^{10}$

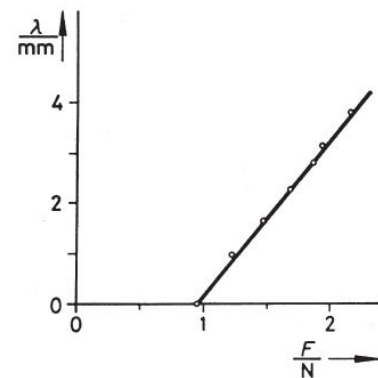


Fig. 4: Bending of a bar as a function of the force (steel,  $L = 0.48$  m,  $a = 10$  mm,  $b = 1.5$  mm).

## Results (2/3)

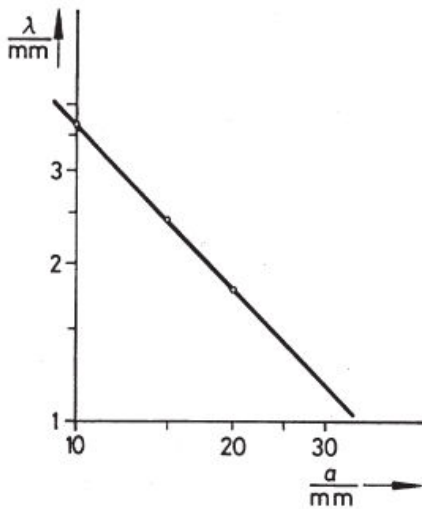
**PHYWE**  
 excellence in science


Fig. 5: Bending of a bar as a function of its width, at constant force (steel, thickness = 1.5 mm).

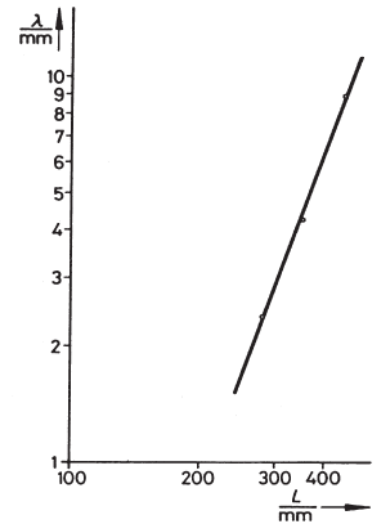


Fig. 6: Bending of a bar as a function of its length, at constant force.

## Results (3/3)

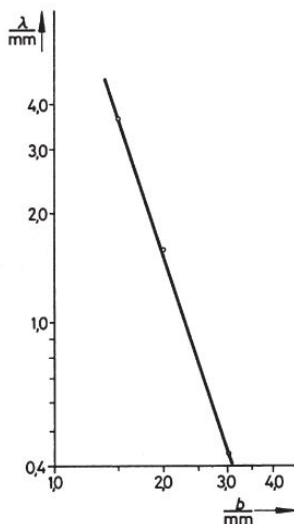
**PHYWE**  
 excellence in science


Fig. 7: Bending of a bar as a function of its thickness, at constant force (steel, width = 10 mm).