

Rectifier circuits



The goal of this experiment is to investigate the principle of a rectifier.

Physics

Electricity & Magnetism

Electronics

Applied Science

Engineering

Electrical Engineering

Properties of Electrical Circuits



Difficulty level

hard



Group size

2



Preparation time

45+ minutes



Execution time

45+ minutes

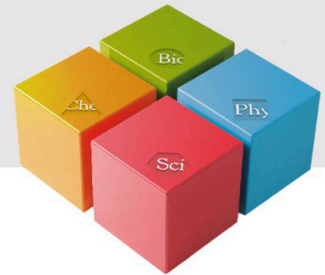

General information

Application

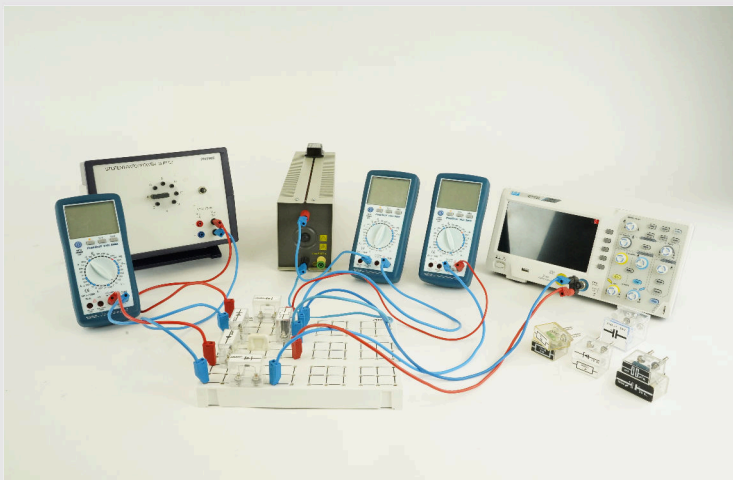

Experimental setup

A rectifier is an electrical device that converts alternating current (AC), which periodically reverses direction, to direct current (DC), which flows in only one direction.

Rectifiers have many uses but are often found serving as components of DC power supplies and high-voltage direct current power transmission systems. Rectification may serve in roles other than to generate direct current for use as a source of power. As noted, detectors of radio signals serve as rectifiers. In gas heating systems flame rectification is used to detect presence of a flame.

Other information (1/3)

PHYWE
excellence in sciencePrior
knowledge

The prior knowledge required can be found in the theory section.

Scientific
principle

The ripple of the output voltage of various rectifier circuits is measured as a function of the load current strength and the charging capacitance. The characteristics of a voltage stabilizer and of a multiplier are investigated.

Other information (2/3)

PHYWE
excellence in scienceLearning
objective

The goal of this experiment is to investigate the principle of a rectifier.

Tasks



- Using the half-wave rectifier: display the output voltage (without charging capacitor) on the oscilloscope, measure the diode current I_D as a function of the output current strength I_0 (with the charging capacitor), measure the ripple component $U_{AC,pp}$ of the output voltage as a function of the output current ($C = \text{constant}$), measure the ripple as a function of the capacitance ($I_0 = \text{constant}$), measure the output voltage U_0 as a function of the input voltage U_i $I_0 = 0$.

Other information (3/3)

PHYWE
excellence in science

Tasks



- Using the bridge rectifier: display the output voltage (without charging capacitor) on the oscilloscope, measure the diode current I_D as a function of the output current strength I_0 (with the charging capacitor), measure the ripple of the output voltage as a function of the output current ($C = \text{constant}$), measure the ripple as a function of the capacitance ($I_0 = \text{constant}$), measure the output voltage as a function of the input voltage.
- Measure the voltage at the charging capacitor, U_C , and the output voltage of a stabilized voltage source as a function of the input voltage U_i .
- Measure the output voltage of a voltage multiplier circuit as a function of the input voltage.

Theory (1/2)

PHYWE
excellence in science

In a half-wave rectifier (Fig. 2), only the positive half-waves of the input alternating voltage appear at the output, i.e. If there is no charging capacitor we obtain a pulsating direct voltage.

When the charging capacitor C is connected, it becomes charged to the peak value of the alternating voltage $U_o = \sqrt{2} \cdot U_{i,\text{rms}}$ during the positive half-wave. As soon as the input voltage falls below the output voltage the diode blocks the circuit. The maximum inverse voltage at the diode is

$$U_{\text{inv. max}} = 2\sqrt{2}U_{i,\text{rms}}$$

On load, the load resistor discharges the capacitor as long as the rectifier continues to block. The output voltage then consists of a direct voltage superimposed on an alternating voltage (ripple) $U_{AC,pp}$. The ripple amplitude is given by

$$U_{AC,pp} \sim \frac{I_0}{C \cdot f'}$$

Theory (2/2)

where C is the charging capacitance and f the frequency of the alternating voltage. The frequency of the ripple f' in the half-wave rectifier is $f' = f = 50 \text{ Hz}$.

In full-wave rectification in the bridge circuit (Graetz rectifier), the diodes connect the negative pole of the voltage source to earth and the positive pole to the positive pole of the capacitor. Every half-wave is thus utilised.

The maximum voltage at a diode is then

$$U_{i.v. \max} = \sqrt{2}U_{i,rms}$$

Equipment

| Position | Material | Item No. | Quantity |
|----------|-----------------------------------------------------------------------------------|------------|----------|
| 1 | Plug-in board, for 4 mm plugs | 06033-00 | 1 |
| 2 | Semiconductor diode Si, 1 N 4007, case G1 | 39106-02 | 4 |
| 3 | Electr.capaci. 470 microF/35V,G1 | 39105-26 | 1 |
| 4 | Electrol.capacitor10microF/35V,G1 | 39105-28 | 4 |
| 5 | Electrolyte capacitor 2000 µF/35V, G2 | 39113-08 | 1 |
| 6 | Capacitor,electr.1mF/35V,G1 | 06049-09 | 1 |
| 7 | Resistor 470 Ohm, 1W, G1 | 39104-15 | 1 |
| 8 | Resistor 47 Ohm, 1W, G1 | 39104-62 | 1 |
| 9 | Low power zener diode ZF 4,7, G1 | 39132-01 | 1 |
| 10 | PHYWE Multitap transformer DC: 2/4/6/8/10/12 V, 5 A / AC: 2/4/6/8/10/12/14 V, 5 A | 13533-93 | 1 |
| 11 | Digital storage oscilloscope, 20 MHz, 2 channels, 100 MS/s | EAK-P-1335 | 1 |
| 12 | Digital multimeter, 600V AC/DC, 10A AC/DC, 20 MΩ, 200 µF, 20 kHz, -20°C... 760°C | 07122-00 | 3 |
| 13 | Rheostat, 330 Ohm , 1.0A | 06116-02 | 1 |
| 14 | Adapter, BNC male/4 mm female pair | 07542-26 | 1 |
| 15 | Short-circuit plug, white | 06027-06 | 3 |
| 16 | Connecting cord, 32 A, 250 mm, red | 07360-01 | 2 |
| 17 | Connecting cord, 32 A, 250 mm, blue | 07360-04 | 2 |
| 18 | Connecting cord, 32 A, 500 mm, red | 07361-01 | 4 |
| 19 | Connecting cord, 32 A, 500 mm, blue | 07361-04 | 4 |

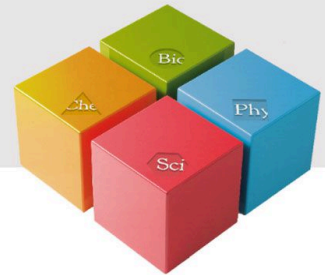

Setup and Procedure

Setup and Procedure (1/3)



Fig. 1: Experimental setup

Set up the experiment on the universal plug-board in accordance with Fig. 1 and the circuit diagrams in Figs. 2 to 5.

The output current is varied by the load resistor R_L . Care should be taken that the current does not exceed the maximum permissible I_A through the silicon diodes.

Setup and Procedure (2/3)

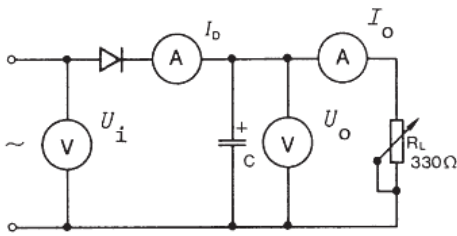

Fig. 2: Half-wave rectifier circuit.

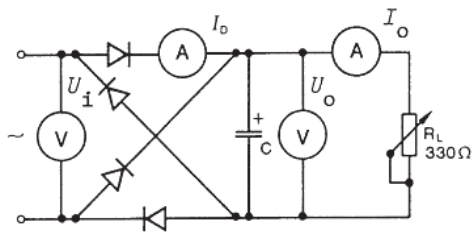

Fig. 3: Experimental bridge rectifier circuit.

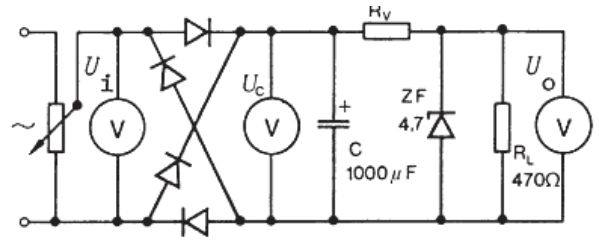

Fig. 4: Experimental voltage stabiliser circuit.

Setup and Procedure (3/3)

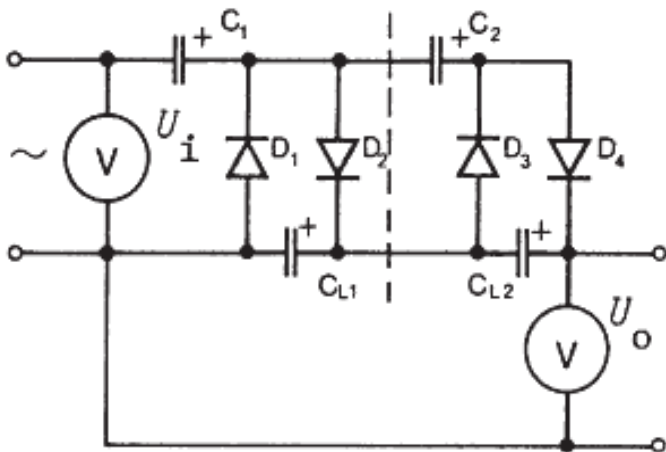

Fig. 5: Voltage multiplier circuit.

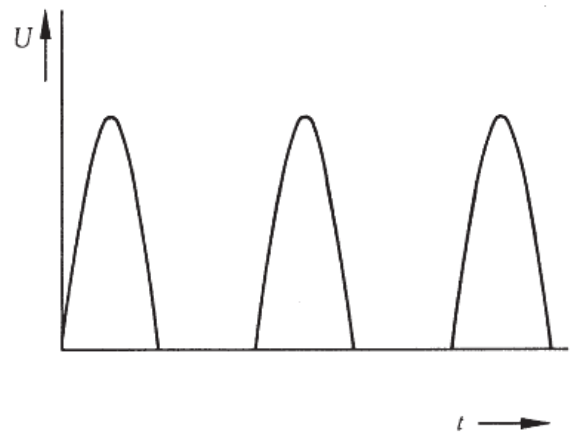
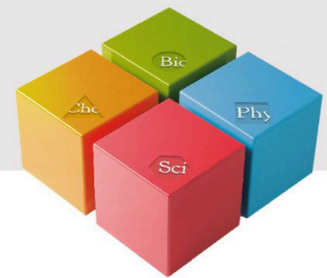

Fig. 6: Output alternating voltage of a half-wave rectifier, $f = 50 \text{ Hz}$.



Evaluation

Task 1 (1/4)

Applying the expression

$$U_{AC,pp} = a \cdot C^b$$

to the measured values from Fig. 8, we obtain

$$b_1 = -0.89 \pm 0.02 \text{ (bridge rectifier)}$$

$$\text{and } b_2 = -0.94 \pm 0.04 \text{ (half-wave rectifier)}$$

This shows, within the limits of error, that ripple is inversely proportional to capacitance. (Note; the capacitance values given for electrolytic capacitors are subject to a tolerance of -10% to +50%)

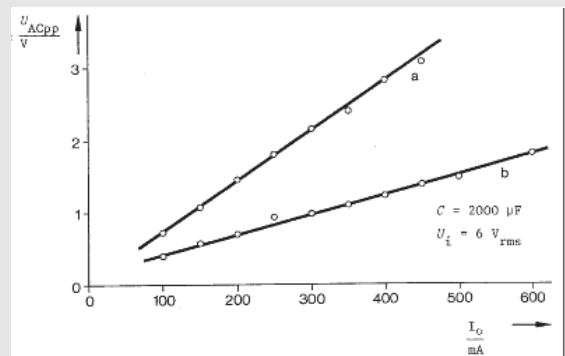

Fig. 7: Ripple of the output voltage as a function of the charging current: a) half-wave rectifier, b) bridge rectifier.

Task 1 (2/4)

 PHYWE
excellence in science

For the half-wave rectifier on no-load the output voltage is

$$U_o = \sqrt{2}U_{i,rms} - U_D$$

where U_D is the forward voltage of the diode (between 0.5V and 0.8V in the case of silicon diodes).

From the regression lines and measured values in Fig. 9 we obtain the following, using the expression:

$$U_o = a + bU_{i,rms}$$

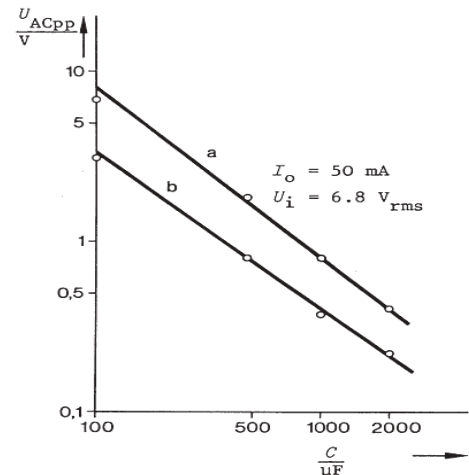

Fig. 8: Ripple as a function of capacitance: a) half-wave rectifier b) bridge rectifier.

Task 1 (3/4)

 PHYWE
excellence in science

Half-wave rectifier:

$$a = -0,6 \text{ V} \Rightarrow U_D = (0.6 \pm 0.1) \text{ V}$$

$$s_a = 0.1 \text{ V}, b = 1.45, s_b = 0.01$$

Bridge rectifier

$$a = -1.1 \text{ V} \Rightarrow U_D = (0.55 \pm 0.05) \text{ V}$$

$$s_a = 0.1 \text{ V}, b = 1.45, s_b = 0.01$$

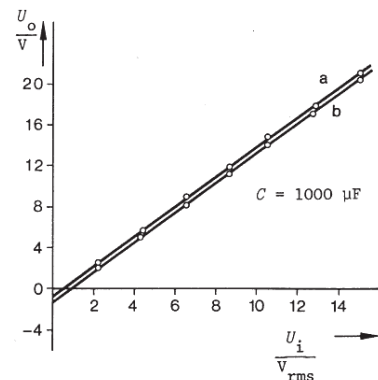

Fig 9: Output voltage (no-load) as a function of the input voltage: a) half-wave rectifier, b) bridge rectifier.

Task 1 (4/4)



 PHYWE
excellence in science

Fig 10: Output voltage of the bridge rectifier (without charging capacitor), frequency 100 Hz.

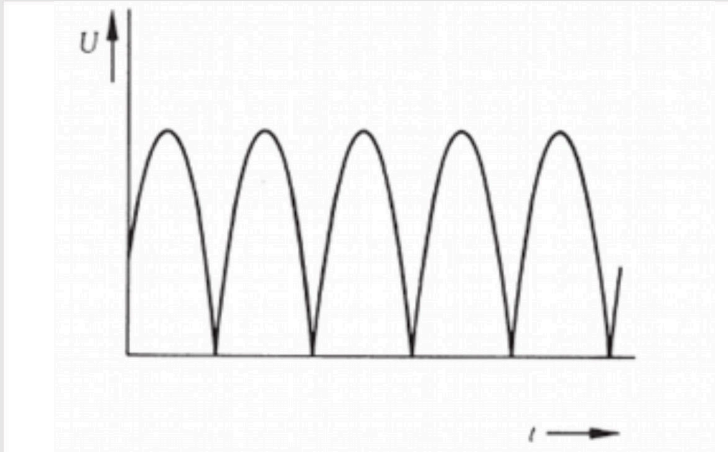
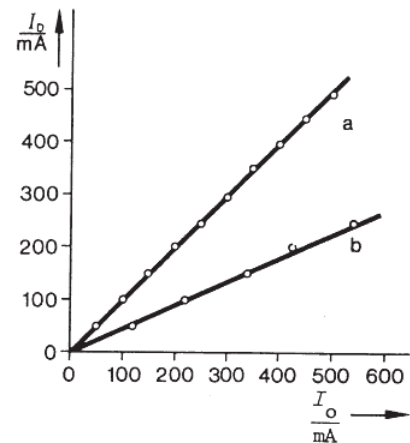

Fig 11: Diode current as a function of the output current: a) half-wave rectifier, b) bridge rectifier.

Task 2

 PHYWE
excellence in science

Contrary to the action of the half-wave rectifier, the r.m.s. current flowing through a diode in a fullwave rectifier is half the output current as only one pair of diodes is switched in at any time during a half-cycle. Fig. 11 confirms this relationship: $I_D = g(I_o)$ gives a straight line of gradient 1 in the case of a half-wave rectifier, but of gradient 0.5 in the case of a bridge rectifier.

$$U_{AC,pp} \sim \frac{I_o}{2C \cdot f}$$

The measured values in Fig. 7 and 8 confirm this. As two series-connected diodes are driven in the conducting direction in each half-wave, the output voltage

$$U_o = \sqrt{2}U_{i,rms} - U_D$$

Task 3

 PHYWE
 excellence in science

If U_C (Fig. 4) exceeds the Zener voltage of 4.7V, the current increases to such an extent that the voltage at the diode remains almost constant because of the voltage drop over R_V . The stabilization factor (smoothing factor) can be obtained from the gradient of the U_Q curve (Fig. 12).

For a point above approx. 6V we obtain

$$G = \frac{\Delta U_C}{\Delta U_o} = 13$$

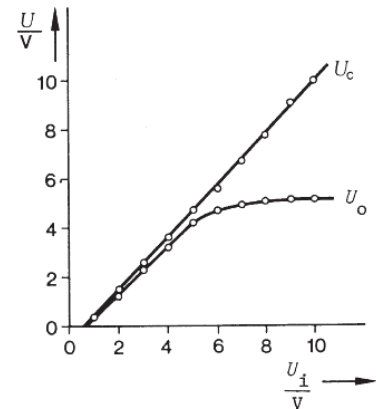

Fig 12: Capacitor voltage U_C and output voltage U_o of the circuit in Fig. 4.

Task 4

 PHYWE
 excellence in science

Voltage multipliers are used to generate high voltages at low current consumption. The Greinacher rectifier (cascade connection) shown in Fig. 5 consists of $n = 2$ cascades. Each stage generates a direct voltage $U = 2 \cdot \sqrt{2} \cdot U_{i,rms}$ across C_L : n times the voltage thus reaches the capacitors arranged in series C_L . For the unloaded voltage, U_o :

$$U_o = 2n\sqrt{2}U_{i,rms} - 2nU_D$$

Applying the regression expression $U_o = a + b \cdot U_{i,rms}$ to the measured values in Fig. 13 we obtain:

$$a = -3.8 \text{ V} \Rightarrow U_D = (0.9 \pm 0.02) \text{ V}$$

$$s_a = 0.9 \text{ V}, s_b = 0.1, b = 5.9 \Rightarrow n = 2.09 \pm 0.04$$

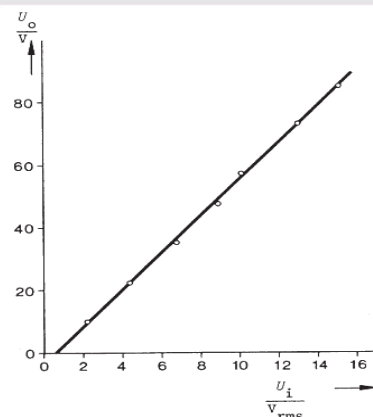

Fig. 13: Output voltage as a function of the input voltage in the Greinacher rectifier in Fig. 5