

# Kirchhoff's Laws: Kirchhoff's Current Law with Cobra SMARTsense

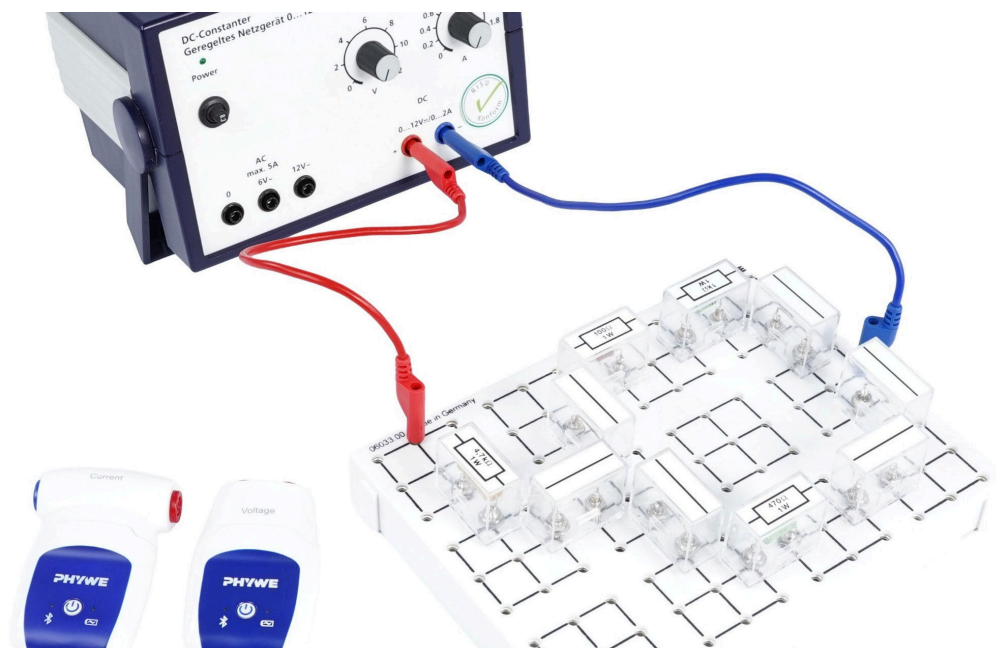

Physics

Electricity &amp; Magnetism

Simple circuits, resistors &amp; capacitors



Difficulty level

easy



Group size

-



Preparation time

10 minutes



Execution time

20 minutes

This content can also be found online at:

<https://www.curriculab.de/c/69834b644ea2f00002082871>

PHYWE

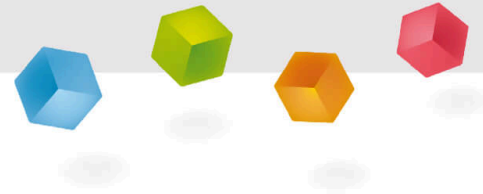

## Teacher information

## Application

PHYWE

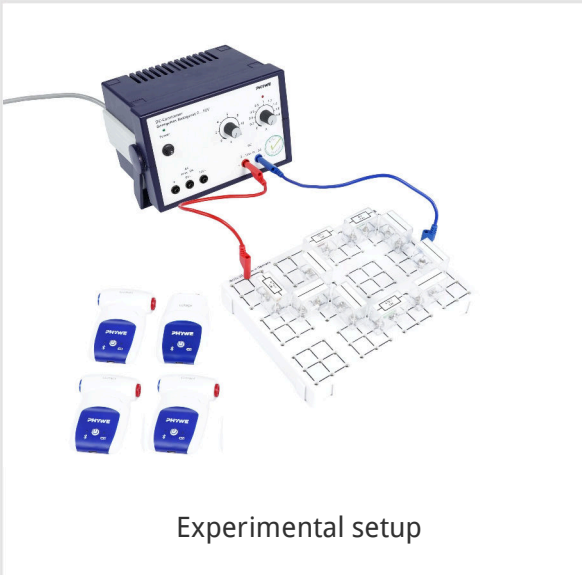

Experimental setup

Kirchhoff's laws are central tools for analysing electrical circuits. The first law, the current rule, states that at every branching point in a circuit, the sum of the incoming currents is equal to the sum of the outgoing currents. No charge is lost. The 2nd law, the voltage rule, states that the sum of all voltages in a closed loop is zero.

This makes the energy distribution in a circuit comprehensible. Both laws are essential for calculating and optimising complex networks.

The knot rule is derived in this experiment.

## Other teacher information (1/2)

PHYWE

### Prior knowledge



Pupils should be able to build a circuit independently. They should also have a basic understanding of electrical quantities such as voltage, current and resistance.

### Principle



In the experiment, a circuit is set up in which various resistors are connected in such a way that the node rule can be worked out independently. To do this, the currents at the node are measured and added or subtracted.

## Other teacher information (2/2)

PHYWE

### Learning objective



The aim of the experiment is to learn about the distribution of currents in an electrical circuit.

### Tasks



In this experiment, the currents flowing into and out of the nodes will first be measured. Based on these measurement results, Kirchhoff's current law will then be derived.

## Safety instructions

PHYWE



The general instructions for safe experimentation in science lessons apply to this experiment.

PHYWE

## Student information

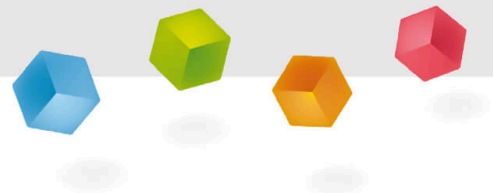

## Motivation

PHYWE



Have you ever wondered how electricity really flows through the wires in your house? That's exactly what you'll find out in our experiment! Kirchhoff's current law allows us to calculate the current in any circuit, even if several components are connected to each other.

Understand this law for yourself and find out how current behaves in circuits. Kirchhoff's laws are much more than just theory - they are the basis for almost every electrical application.

## Tasks

PHYWE

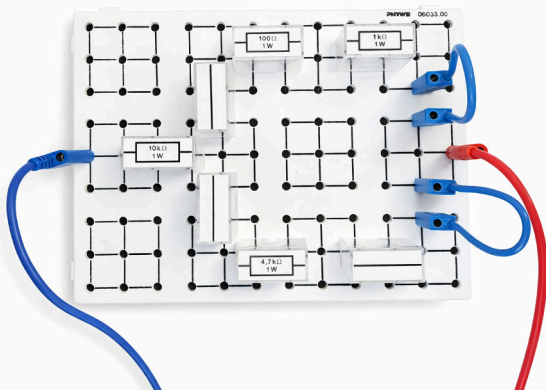

Experimental setup

1. Build a circuit with resistors and junctions.
2. Determine the current before and after a node.
3. Determine the voltage across a resistor and calculate the current.
4. Work out the current law.

## Equipment

Position	Material	Item No.	Quantity
1	Plug-in board, for 4 mm plugs	06033-00	1
2	Cobra SMARTsense Voltage - Sensor for measuring electrical voltage $\pm$ 30 V (Bluetooth + USB)	12901-02	1
3	Cobra SMARTsense Current - Sensor for measuring electrical current $\pm$ 1 A (Bluetooth + USB)	12902-02	3
4	PHYWE Power supply, 230 V,DC: 0...12 V, 2 A / AC: 6 V, 12 V, 5 A	13506-93	1
5	Connecting cord, 32 A, 250 mm, red	07360-01	6
6	Connecting cord, 32 A, 250 mm, blue	07360-04	6
7	Resistor 10 kOhm, 1W, G1	39104-30	1
8	Resistor 4.7 kOhm, 1W, G1	39104-27	1
9	Resistor 1 kOhm, 1W, G1	39104-19	1
10	Resistor 100 Ohm, 1W, G1	39104-63	1
11	Wire building block, housing G1	39120-00	3

## Setup (1/2)

PHYWE

For measurement with the **Cobra SMARTsense sensors** the **PHYWE measureAPP** required. The app can be downloaded free of charge from the relevant app store (see below for QR codes). Before starting the app, please check whether your device (smartphone, tablet, desktop PC) is running **Bluetooth activated** is.



iOS



Android



Windows

## Setup (2/2)

PHYWE

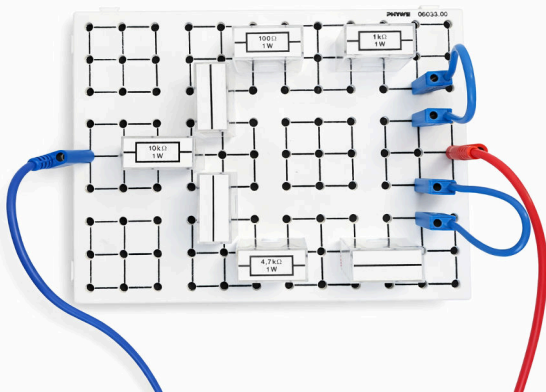

Experimental setup

- Set up the experiment as shown in the diagram.
- Set the power supply unit to approx. 6 V and 1 A and switch it on.

## Procedure (1/3)

PHYWE





Cobra SMARTsense sensors

- Switch on your Cobra SMARTsense sensors by pressing and holding the button on the sensors for 3 seconds.
- Open the measureAPP on your tablet or smartphone and make sure that the end device can connect to Bluetooth devices.
- Connect all sensors to the app by selecting the Cobra SMART Current and Voltage sensors under Sensors.
- Set the sampling frequency to 10,000 Hz in the measureAPP under Configuration.

## Procedure (2/3)

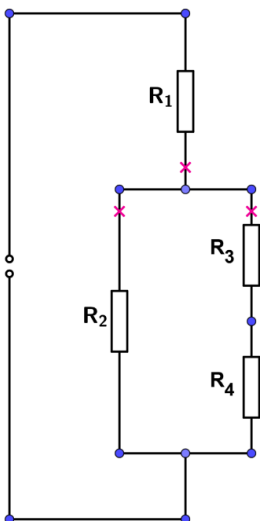
PHYWE



- Using the Cobra SMARTsense Current sensors, measure the current at the points shown as pink crosses.
- Use the digital display in the measureAPP for this. To do this, click on the centre box above the measurement data, which is labelled 0.0.
  - 
- Then enter the values determined under task (1/3) in the report section.
- Can you already see how the current behaves at the node?

## Procedure (3/3)

PHYWE

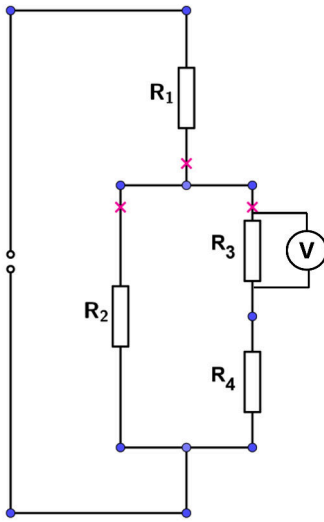

- Now use the Cobra SMARTsense Voltage Sensor to measure the voltage via the resistor  $R_3$ .
- Use the digital display in the measureAPP for this. To do this, click on the centre box above the measurement data, which is labelled 0.0.
  - 
- Then enter the determined value under task (3/3) in the report section.

PHYWE

## Report

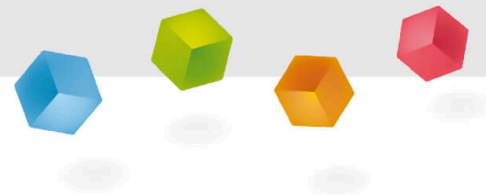

### Task (1/3)

PHYWE

Enter the measured currents in the appropriate boxes. Can you recognise a connection between the values?

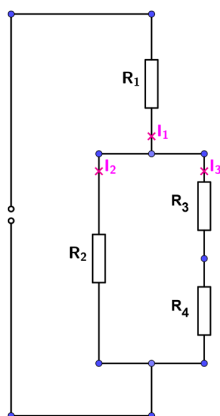

$I_1 =$

$I_2 =$

$I_3 =$

Which of the following relationships applies to the currents  $I$  you have determined?

$(I_2 + I_3)/I_1 = 0$

$I_1 = I_2 = I_3$

$I_1 \cdot I_2 \cdot I_3 = 100A$

$I_1 = I_2 + I_3$

### Task (2/3)

PHYWE



Fill in the missing words.

Kirchhoff's first law is the current law. It states that the  of all currents flowing into a node (connection point of lines) is equal to the sum of all currents . By definition, the current flowing in is  and the current flowing out is negative. Therefore, the total sum of the currents at a node is always . This means that no electrical charge is generated or destroyed at a node. The law of charge  applies.

Check

### Task (3/3)

PHYWE

Write down the measured voltage  $U_3$  at the resistance  $R_3$  into the box. Calculate the current using Ohm's law and enter it in the box.

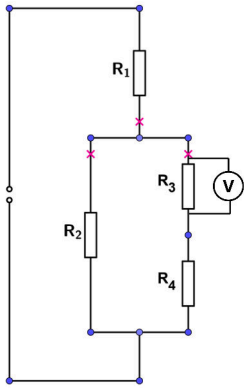

$$U_3 = \boxed{\phantom{000}}$$

$$I_{3,\text{calculated}} = \boxed{\phantom{000}}$$

How does the calculated current differ from the measured current? Why?

Slide	Score/Total
Slide 16: Current correlations	0/1
Slide 17: The knot rule	0/5

Total amount  ★ 0/6

👁 Solutions

🔄 Repeat

📄 Export text